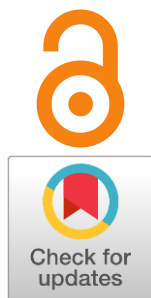

Influence of alloying parameters on the structure and properties of AK-6 aluminium alloy

Aleksandr Filatov^{a*}Received: 21 April 2024
Accepted: 22 May 2024
Published online: 3 June 2024DOI: [10.15826/elmattech.2024.3.034](https://doi.org/10.15826/elmattech.2024.3.034)

This work is devoted to the study of the effect of zirconium addition and crystallization rate on the structure and properties of industrial aluminium alloys. Experimental alloying of the AK6 alloy was performed. The required amount of Al-Zr-10 alloy (10 wt. % Zr) was added at a temperature of 900 °C until the zirconium content in the target alloy reached 0.1; 0.3; 0.5 wt. %. According to the results of scanning electron microscopy and X-ray diffraction analysis, the main proportion of zirconium in the initial alloy was represented by intermetallic compounds of predominantly Al₃Zr composition and sizes from 5 to 50 μm. Values of microhardness measured after direct alloying of high-purity aluminium with zirconium by the electrolysis of oxide-fluoride melts demonstrate that at a zirconium content of 0.4 wt. %, the microhardness of the alloy increases by 1.5 times and continues to grow as the zirconium content increases. Based on the results of structural analysis, it was found that the average grain size of the aluminium alloy decreased by 4–5 times even at a Zr content of 0.1 wt. %. When studying the properties of the obtained samples, it was found that the addition of zirconium to the AK6 alloy does not affect its hardness, in contrast to high-purity aluminium, which is presumably due to the more pronounced influence of other components and the absence of an additive effect of zirconium on the alloy hardness. Accelerated cooling of the alloy to 10³ K/s without zirconium additives has a similar effect of grain reduction, and also increases the microhardness of the alloy by 10 HB according to Brinell. A study of the combined effect of zirconium addition and accelerated cooling shows the additive effect of grinding by more than 25 times, while individual grains do not exceed 5 microns in size. The absence of intermetallic compounds in the obtained samples of the AK6 alloy after modification with the Al-Zr alloy indicates that the phase composition of the initial Al-Zr alloy does not affect the properties of the target alloys.

keywords: electrolysis, modification, crystallization, structure, aluminium, alloy, hardness

© 2024, the Authors. This article is published in open access under the terms and conditions of the Creative Commons Attribution (CC BY) license <http://creativecommons.org/licenses/by/4.0/>.

1. Introduction

Currently, the demand for aluminium is significantly increasing, and the requirements for multicomponent aluminium-based alloys and materials are becoming stricter [1–4]. Aluminium alloys with zirconium additives are mainly used in aircraft construction and power generation [5–7], since the Zr content in aluminium alloys within 0.2 wt. % significantly improves the technological characteristics of the alloy, without changing the density and electrical conductivity [8, 9]. The most common method of producing these alloys is their dissolution in the aluminium base [10, 11]. The main feature of

aluminium-zirconium alloys is the presence of intermetallic compounds of variable composition and size [12–16], which is not acceptable in industrial alloys. Therefore, the question of the influence of the phase composition of the feedstock on the structure and properties of the target industrial alloys arises [17]. In addition to alloying, the thermophysical parameters of the casting process or heat treatment of finished products also have a significant impact on the structure of metals [18]. Since the scientific and technical literature has very limited data on the combined effect of zirconium addition and crystallization rate on the structure and properties of industrial aluminium alloys, the study of this issue is relevant. In this work, the influence of the zirconium content and crystallization rate on the structure and properties of industrial aluminium alloys was studied.

^a: Institute of High Temperature Electrochemistry, Ural Branch of the Russian Academy of Sciences, Ekaterinburg 620066, Russia

* Corresponding author: Aleksander.F.A@yandex.ru

2. Experimental

The influence of the alloying process was studied using the example of the Al-Si-Fe (AK6) alloy modification (LLC "METALLURGICAL INDUSTRY"). The elemental composition of the AK6 alloy is presented in Table 1.

The initial Al-Zr master-alloy was obtained by the experimental method of molten oxide-fluoride mixtures electrolysis. A batch of alloys with a zirconium content of 0.1 to 2 wt. % and Al-Zr master alloy ingots with zirconium content ranging from 2 to 10 wt. % were obtained by the electrolysis of oxide-fluoride melts. The alloy modification was carried out in a high-temperature chamber electric furnace PVK-1.4 25. The graphite crucibles with alloy ingots were placed in a furnace and heated to 900 °C, after which the required amount of Al-Zr alloy was added. The alloy was exposed for 10 minutes at 900 °C, after which it was stirred with a graphite stirrer, and a part of the alloy was poured into a rapid quenching unit and the rest into a graphite mold.

Figure 1 shows a rapid quenching installation, which is a slot mold rotating at speeds of up to 3000 rpm. The installation consists of two cooling copper disks with a gap between them and a graphite supercharger, which ensures uniform filling of the space between the disks. After complete cooling, the resulting alloy samples were removed from the installation and analyzed for elemental and phase compositions, as well as for microstructural peculiarities. To determine the microstructure and estimate the grain size, the resulting alloys were split into thin sections using cutting and grinding equipment (Struers, Denmark); then the surfaces of the samples were etched in a 10 % aqueous solution of hydrofluoric acid and studied on a Quanta-200 scanning electron microscope (BSE sensor) with an EDAX attachment and optical microscope Neophot-2I (FET Company, USA). An optical microscope was chosen to analyze the alloy surface after etching in more detail. The volume fraction of phases and the size of intermetallic inclusions were determined by the standardized methods of quantitative analysis using computer programs in the Siams-700 metallurgical complex. The macrostructure was studied using a Micromed MC2 Zoom 2CR binocular microscope (Micromed Company, Russia). The hardness of the samples was measured on a TSh-2m hardness tester (Ziptest Company, Russia) following the Certification system GOST 9012-59 according to the Brinell scale at a load of 2500N and a ball diameter of 5 mm. The phase and elemental composition of the resulting alloys was determined by the X-ray diffraction analysis using a Rigaku D/MAX-2200VL/PC diffractometer (Rigaku,

Table 1 – Composition of the studied AK6 alloy (wt. %).

Components	Content	Components	Content
Fe	0.7	Al	93.3–96.7
Si	0.7–1.2	Cu	1.8– 2.6
Mn	0.4–0.8	Mg	0.4–0.8
Ni	0.1	Zn	0.3
Ti	0.1	Rest	Total 0.1

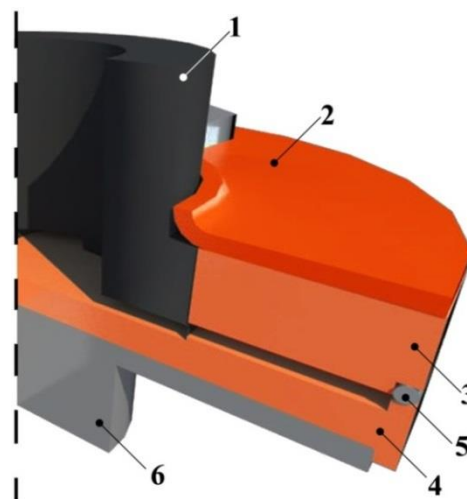

Figure 1 Scheme of the rapid quenching installation: 1 – graphite supercharger; 2 – pressure disk; 3 – upper cooling disk; 4 – lower cooling disk; 5 – external sealing ring; 6 – electric motor flange.

Japan) and the atomic emission method with inductively coupled plasma using an iCAP 6300 Duo spectrometer (Thermo scientific, USA) respectively.

3. Results and discussion

A typical microphotograph of a thin section of the Al-Zr-10 alloy (10 wt. % Zr) is presented in Figure 2.

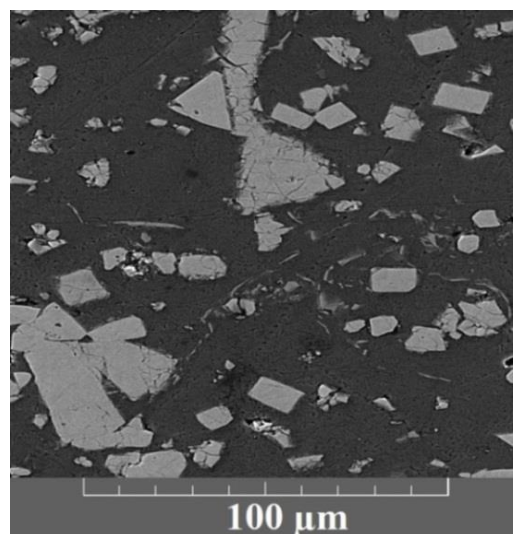

Figure 2 Microphotograph of Al-Zr alloy containing 10 wt. % Zr.

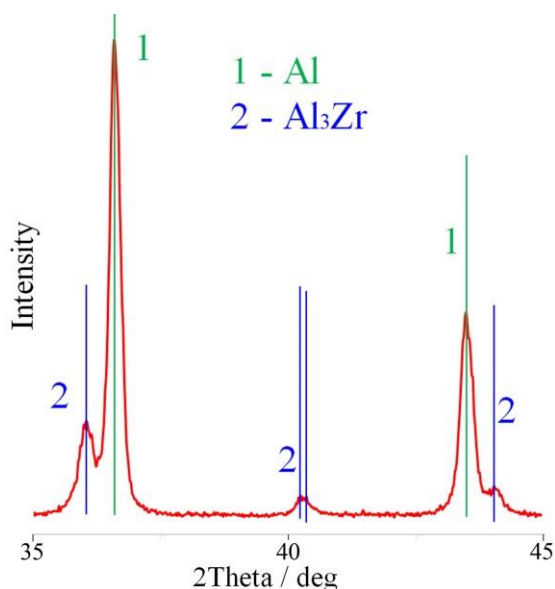

Figure 3 Diffraction pattern of the Al-Zr alloy containing 10 wt. % Zr.

According to the obtained microphotographs and the results of X-ray diffraction analysis (Figure 3), the main proportion of zirconium in the alloy is contained in the form of intermetallic compounds predominantly of the Al_3Zr composition ranging in size from 5 to 50 microns.

The obtained values of microhardness measurements during direct alloying of high-purity aluminium with zirconium by the electrolysis of oxide-fluoride melts elucidate that at a zirconium content of 0.4 wt. %, the microhardness of the alloy increases by 1.5 times and it continues to grow as the zirconium content increases [9].

To study the effect of zirconium additives on the structure and properties of industrial aluminum alloys, the ingots of AK6 alloys with the following zirconium concentrations 0.1, 0.3 and 0.5 wt. % were obtained at normal cooling rate.

Figure 4 shows the results of the X-ray diffraction analysis of the obtained AK6 alloys without the addition of zirconium and with a zirconium content of 0.1 wt. %. It is clearly seen that after alloying the target alloy does not contain any intermetallic compounds that were present in the original alloy, which is consistent with the phase diagrams of the Al-Zr system.

A study of the macrostructure of the obtained samples showed that the effect of grain refinement of the aluminum alloy occurs at a zirconium content of 0.1 wt. % (Figure 5), which is consistent with literature data on the effect of zirconium additives on the structure of aluminum alloys [9]. Table 2 shows the calculation results of changes in the average grain size of the AK6 alloy depending on the zirconium content using the Siams-700 program.

The calculation results show a decrease in the average grain size by 4–5 times at a zirconium content in the alloy of 0.1 wt. %, while a further increase in the zirconium content does not affect the structure of the alloy.

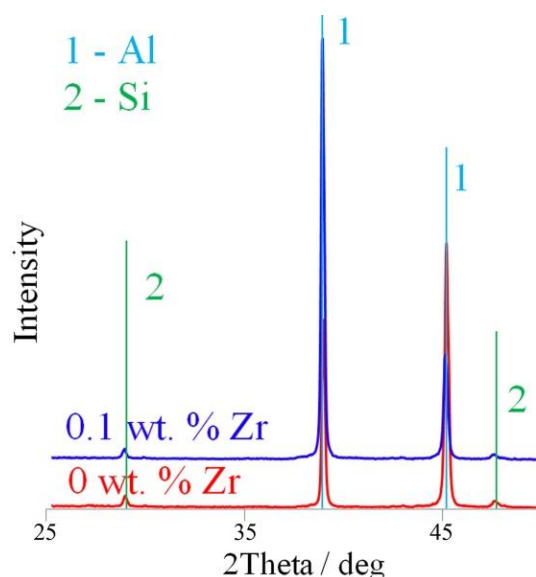

Figure 4 Diffraction pattern of the AK6 alloy with the zirconium content of 0 and 0.1 wt. %.

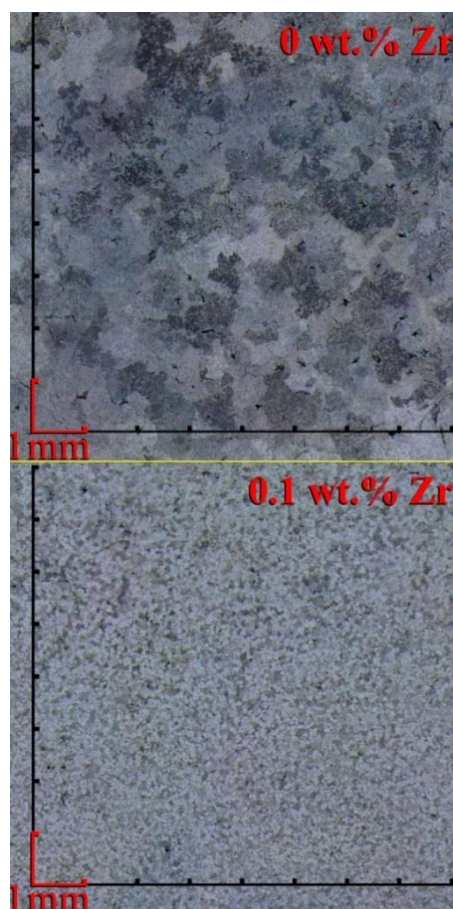

Figure 5 Photographs of the AK6 alloy without the addition of zirconium and with a zirconium content of 0.1 wt. %, obtained by optical microscopy.

Table 2 – Measured AK6 alloy properties depending on zirconium content.

Sample	wt. % Zr	Hardness HB	Grain size, microns
1	0	65.5	1195
2	0.1	65.9	239
3	0.3	66.8	256
4	0.5	68.8	225

A study of the macro and microstructure of the resulting alloys shows that the increasing cooling rate refines multiple the grain times without the addition of zirconium to the AK6 alloy (Figures 6 and 7), while the photographs also show that there are no intermetallic inclusions present in the original alloy. Due to the different cooling rates over the installation area, a visible increase in the grain size at the macro level is observed in the obtained samples from the center to the periphery of the disk (Figure 8). The measured values of the hardness of the obtained samples demonstrate an increase in the microhardness of the alloy by 10 HB according to Brinell.

The combination of zirconium alloying and accelerated cooling was found to result in a multiple, more than 25-fold (Table 3), decrease in the average grain size, with the minimum size of individual grains reaching 5 μm . These facts indicate the additivity of these effects.

To study the combined effect of zirconium addition and crystallization rate on the structure and properties of the alloys, AK6 alloy disks with a diameter of 80 and a thickness of 2 mm, with the zirconium content of 0.1, 0.3, 0.5 wt. % were produced by centrifugal casting at a cooling rate of 10^3 K/s.

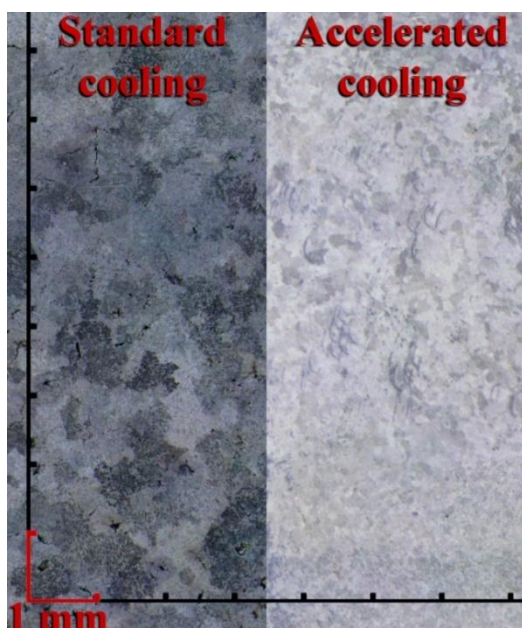
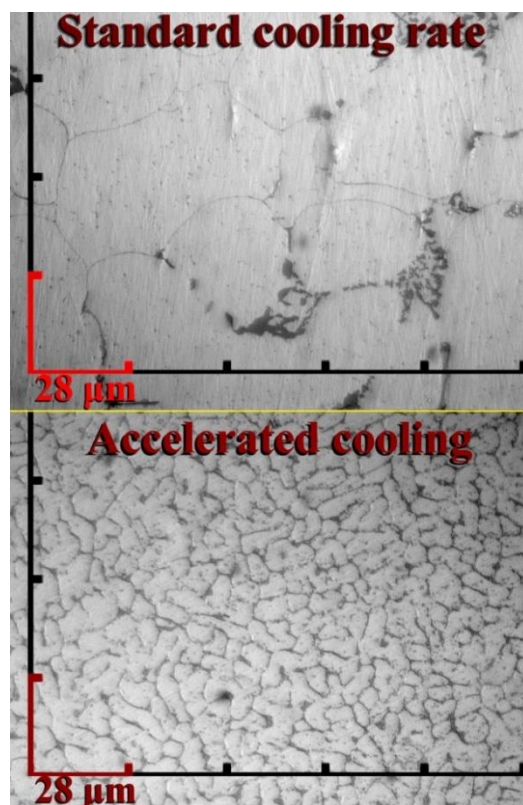
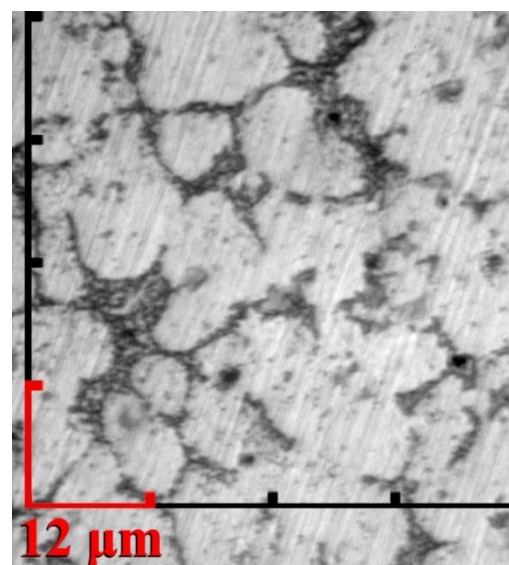
**Figure 6** Photographs of the AK6 alloy without zirconium, obtained at different cooling rates: 1 – standard; 2 – 10^3 K/s, obtained by optical microscopy.**Figure 7** Microphotographs of the AK6 alloy without zirconium additives, obtained at different cooling rates: 1 – standard; 2 – 10^3 K/s.**Figure 8** Microphotograph of the AK6 alloy with a Zr content of 0.5 wt. %, obtained at a cooling rate of 10^3 K/s.**Table 3** – Properties of AK6 alloys with different zirconium contents after quenching.

Sample	wt. % Zr	Hardness, HB	Grain size, microns
1	0	77.6	170
2	0.1	77.9	116
3	0.3	77.8	63
4	0.5	77.3	36

The obtained results bring us to the following conclusions:

- industrial alloys can be alloyed with appropriate zirconium-based alloys without additional processing, since the properties of the target product do not depend on the phase composition of the original alloying raw material;

- the addition of 0.1 wt. % zirconium to industrial alloys reduces the grain size but does not affect the hardness of the alloys due to the more pronounced influence of other components and the absence of an additive effect of zirconium on the hardness of the alloy;

- accelerated cooling refines the grain even without adding zirconium to the alloy and also increases the hardness of the alloy by 10 HB according to the Brinell scale;

- the combined use of zirconium alloying and accelerated cooling refines the grain by more than 25 times when the minimum size of individual grains reaches 5 microns, indicating the additivity of these effects.

Based on the results obtained, as well as on the scientific and technical literature data [12–20], it can be assumed that the addition of zirconium and the cooling rate have a similar effect on the structure and properties of other multicomponent aluminium alloys.

4. Conclusions

In this work, the influence of zirconium content and crystallization rate on the structure and properties of AK-6 aluminum-based industrial alloy was studied. The tests were carried out using the example of alloying the AK6 alloy by adding the required amount of Al-Zr-IO alloy (10 wt. % Zr) to obtain a series of samples containing 0.1, 0.3 and 0.5 wt. % Zr. Based on the results of structural analysis, it was found that a decrease in the average grain size of the aluminium alloy by 4–5 times was observed even at a Zr content of 0.1 wt. %. When studying the properties of the obtained samples, it was found that the addition of zirconium to the AK6 alloy does not affect its hardness, in contrast to high-purity aluminum, which is presumably due to the more pronounced influence of other components and the absence of an additive effect of zirconium on the hardness of the alloy. Accelerated cooling of the alloy to 10^3 K/s without zirconium additives has a similar effect of the grain reduction and also increases the microhardness of the alloy by 10 HB according to the Brinell scale. A study of the combined effect of accelerated cooling and zirconium addition shows an additive synergistic (nonlinear) effect of reducing the grain size by more than 25 times, while individual grains do not exceed 5 microns in size, however,

to clarify, it is necessary to study the effect of a larger number of cooling rates and zirconium contents.

Supplementary materials

No supplementary materials are available.

Funding

This research had no external funding.

Acknowledgments

None.

Author contributions

Aleksandr Filatov: Conceptualization; Investigation; Methodology; Data curation; Writing – Original draft; Writing – Review & Editing; Formal Analysis; Visualization.

Conflict of interest

The authors declare no conflict of interest.

Additional information

Author IDs:

Scopus ID [7103403759](https://orcid.org/0000-0001-9395-8848);

ORCID [0000-0001-9395-8848](https://orcid.org/0000-0001-9395-8848).

References

1. Filatov AA, Suzdaltsev AV, Zaikov YuP, Modifying Ability of an Al-Zr Master Alloy, *Rus. Met. (Metally)*, **2021** (2021) 1036–1039. <https://doi.org/10.1134/S0036029521080073>
2. Kononov A, Polyakov E, High-temperature electrochemical synthesis and properties of intermetallic compounds of the Ni-Sc system Part I. Electrochemical behaviour of Sc(III) in chloride-fluoride melts, *Journal of Alloys and Compounds*, **239(2)** (1996) 103–106. [https://doi.org/10.1016/0925-8388\(96\)02209-8](https://doi.org/10.1016/0925-8388(96)02209-8)
3. Yuekun G, Jie L, Shengxiang Q, Yida D, et al., Electrodeposition of alloys and compounds from high-temperature molten salts, *J. of Alloys and Comp.*, **690** (2017) 228–238. <https://doi.org/10.1016/j.jallcom.2016.08.104>
4. Ehsan G, Rahim Y, Keivan A, Touradj E, Production of Al-SiC-TiC hybrid composites using pure and 1056 aluminum powders prepared through microwave and conventional heating methods, *J. of Alloys and Comp.*, **690** (2017) 512–518. <https://doi.org/10.1016/j.jallcom.2016.08.145>
5. Rajagopalan PK, Sharma IG, Krishnan TS, Production of Al-Zr master alloy starting from ZrO₂, *J. of Alloys and Comp.*, **285(1–2)** (1999) 212–215. [https://doi.org/10.1016/S0925-8388\(98\)00754-3](https://doi.org/10.1016/S0925-8388(98)00754-3)
6. Emilia K, Vladimir D, Jan H, Advanced technology for Al-Zr alloy synthesis: Electrochemical investigation of suitable

low-melting electrolytes, *J. of Alloys and Comp.*, **738** (2018) 151–157. <https://doi.org/10.1016/j.jallcom.2017.12.136>

7. Ravi KK, Pridhar T, Sree Balaji VS, Mechanical properties and characterization of zirconium oxide (ZrO₂) and coconut shell ash (CSA) reinforced aluminium (Al 6082) matrix hybrid composite, *J. of Alloys and Comp.*, **765** (2018) 171–179. <https://doi.org/10.1016/j.jallcom.2018.06.177>

8. Suzdaltsev AV, Pershin PS, Filatov AA, Nikolaev AYu, et al., Review-Synthesis of Aluminum Master Alloys in Oxide-Fluoride Melts: A Review, *JES*, **167(10)** (2020) 102503. <https://doi.org/10.1149/1945-7111/ab9879>

9. Filatov AA, Suzdaltsev AV, Zaikov YuP, Production of Al-Zr Master Alloy by Electrolysis of the KF-NaF-AlF₃-ZrO₂ Melt: Modifying Ability of the Master Alloy, *MMTB*, **52(6)** (2021) 4206–4214. <https://doi.org/10.1007/s11663-021-02340-1>

10. Filatov AA, Pershin PS, Suzdaltsev AV, Nikolaev AYu, et al., Synthesis of Al-Zr Master Alloys via the Electrolysis of KF-NaF-AlF₃-ZrO₂ Melts, *JES*, **165(2)** (2018) E28. <https://doi.org/10.1149/2.0571802JES>

11. Suzdaltsev AV, Filatov AA, Nikolaev AYu, Pankratov AA, et al., Extraction of Scandium and Zirconium from their oxides during the electrolysis of oxide-fluoride melts, *Rus. Met. (Metally)*, **2018(2)** (2018) 133–138. <https://doi.org/10.1134/S0036029518020180>

12. Pershin PS, Kataev AA, Filatov AA, Suzdaltsev AV, et al., Synthesis of Al-Zr Alloys Via ZrO₂ Aluminum-Thermal Reduction in KF-AlF₃-Based Melts, *MMTB*, **48** (2017) 1962–1969. <https://doi.org/10.1007/s11663-017-0976-y>

13. Tkacheva OYu, Brodova IG, Arkhipov PA, Zaikov YuP, Effect of crystallization conditions on structure and modifying ability of Al-Sc alloys, *Izvestiya. Non-Ferrous Metallurgy*, **6** (2016) 55–64. (In Russian). <https://doi.org/10.17073/0021-3438-2016-6-55-64>

14. Xiaojing X, Xiaopeng J, Zheng L, Bin Z, et al., Influence of large amount Zn on mechanical properties and corrosion resistance of 5083 hot rolled aluminum alloy, *App. Phys. A*, **126** (2020) 713. <https://doi.org/10.1007/s00339-020-03908-5>

15. Xiaojing X, Xiaopeng J, Zheng L, Bin Z, et al., Microstructure and properties of a new Al-Cu-Mg-Zn-Zr-Ti heat resistant aluminum alloy, *Mater. Res. Express*, **6(12)** (2019) 1265h8. <https://doi.org/10.1088/2053-1591/ab6c03>

16. Wang F, Eskin DG, Khvan AV, Starodub KF, et al., On the occurrence of a eutectic-type structure in solidification of Al-Zr alloys, *Scripta Mater.*, **133** (2017) 75–78. <https://doi.org/10.1016/j.scriptamat.2017.02.027>

17. Chikova OA, Boris VO, Pavel LR, The Study of the Dissolution AlZr₂ Ligatures in the Liquid Alloy AlMg6Mn1, *Mater. Sci. Forum*, **870** (2016) 243–247. <https://doi.org/10.4028/www.scientific.net/MSF.870.243>

18. Krokhin AY, Mann VK, Ryabov DK, Babitskiy NA, Effect of treatment parameters on structure, mechanical and corrosion properties of Al-Mg-Sc alloy forgings with reduced concentration of scandium, *The Minerals, Metals and Materials Series Part F4*, (2018) 1573–1580. https://doi.org/10.1007/978-3-319-72284-9_205

19. Kang W, Li HY, Zhao SX, Han Y, et al., Effects of homogenization treatments on the microstructure evolution, microhardness and electrical conductivity of dilute Al-Sc-Zr-Er alloys, *J. of Alloys and Comp.*, **704** (2017) 683–692. <https://doi.org/10.1016/j.jallcom.2017.02.043>

20. Elagin VI, Samarina MV, Zakharov VV, Ways for improving the properties of semiproducts from V96Ts-3-type high-strength aluminum alloys of the Al – Zn – Mg – Cu system, *Met. Sci. Heat Treat.*, **51** (2009) 515–521. <https://doi.org/10.1007/s11041-010-9204-y>